

Application Note 44X-1

# Autotrack Combiners

PREPARED BY:

**EMS TECHNOLOGIES, INC.  
SPACE AND TECHNOLOGY - ATLANTA  
660 ENGINEERING DRIVE  
P.O. BOX 7700  
NORCROSS, GA 30091-7700**

© 2002 EMS Technologies, Inc. All Rights Reserved.  
Basic marketing information approved for release.

<b>EMSTechnologies</b>		Application Note 44X-1 ● Autotrack Combiners	
<i>Document Description:</i>	<i>Date:</i>	<i>Revision:</i>	<i>Page:</i>
<b>APPLICATION NOTE</b>	June 2002	—	Page 2 of 19

**TABLE OF CONTENTS**

**1 INTRODUCTION.....3**

**2 TRACKING ANTENNA SYSTEMS.....3**

**3 AUTOTRACK COMBINER OPERATION.....5**

**4 ERROR TERMS AND SPECIFICATIONS FOR AUTOTRACK COMBINERS.....7**

4.1 ERROR ANALYSIS.....7

4.2 OTHER ERROR SOURCES AND REQUIREMENTS .....10

4.3 PRACTICAL CONSIDERATIONS: PHASE TRIMMING .....11

**5 EXAMPLES OF AUTOTRACK COMBINER IMPLEMENTATIONS.....12**

5.1 DUAL PHASE SHIFTER/TEE AUTOTRACK COMBINER .....12

5.2 SWITCHED LINE AUTOTRACK MODULATOR .....14

5.3 PHASE SHIFTER BASED AUTOTRACK MODULATOR .....16

5.4 PHASE SHIFTER ONLY AUTOTRACK MODULATOR.....17

**6 SUMMARY.....19**

<b>EMS Technologies</b>		Application Note 44X-1 ● Autotrack Combiners	
<i>Document Description:</i>	<i>Date:</i>	<i>Revision:</i>	<i>Page:</i>
<b>APPLICATION NOTE</b>	June 2002	—	Page 3 of 19

## 1 Introduction

Modern communications satellites, which employ high-gain multiple-beam antennas, require much more accurate antenna pointing than their predecessors, which used continent-coverage beams. For example, NASA's Advanced Communications Technology Satellite (ACTS) was required to achieve a pointing accuracy of 0.025° worst case in pitch and roll. This level of pointing accuracy, which amounts to a 10-mile pointing error from geosynchronous orbit, cannot be achieved with an open-loop control system. It can only be achieved by placing a set of fixed microwave beacons on the Earth and using a spacecraft antenna which can "lock on" or track these beacons.

The autotrack modulator provides the modern communications satellite with the ability to track these beacons without using any additional channels to the satellite's receivers. It combines the tracking signals with the communications signals in such a way that they can pass through a receiver together and be separated out at the intermediate frequency (in some cases, the "beacon" is just the communications signal itself, from a known fixed-position earth station).

Ferrite-based autotrack modulators are very low loss, highly reliable, and have very low performance drift over life. They also have unique features such as electronically controlled phase trimming for the various paths through the autotrack. EMS has extensive heritage delivering ferrite-based autotrack modulators for demanding spaceflight applications at frequencies through V-band. This Application Note is provided to our customers to describe the basic operation of the autotrack modulator (ATM) and aid the customer in selecting the configuration and specifications best suited to his or her application. The sections below provide:

- an overview of antenna tracking systems
- descriptions of the error terms and specifications associated with ATMs
- descriptions of several typical ferrite-based ATMs built by EMS

## 2 Tracking Antenna Systems

Pointing direction is generally defined in terms of orthogonal angular coordinates off boresight, namely, elevation (up and down) and azimuth (right and left). The angular errors off the desired pointing angle (directly at the earthside beacon) are then denoted as  $\Delta_{az}$  for the azimuth error and  $\Delta_{el}$  for the elevation error. The spacecraft antenna must provide the ability to derive  $\Delta_{az}$  and  $\Delta_{el}$  when pointed near the beacon, as well as to provide the total received signal, which is usually denoted as the sum signal,  $\Sigma$ . A number of methods have been employed to provide this direction-pointing and tracking information. They include:

- **Sequential Lobing:** In this approach the outputs of two antennas which are pointed at slightly different angles are sequentially sampled. The pointing error can then be derived by observing the relative amplitudes of these samples.

	Application Note 44X-1 • Autotrack Combiners		
	Document Description:	Date:	Revision:
<b>APPLICATION NOTE</b>	June 2002	—	Page 4 of 19

- **Conical Scan:** Here an offset feed is continuously rotated, typically rotating about the boresight axis and the amplitude of the resulting signal is observed. When the beacon is exactly on boresight, the amplitude output of the rotating feed is constant.
- **Simultaneous Lobing or Monopulse:** The two methods just described suffer from the disadvantage that their ability to derive the proper error signals is degraded if the amplitude of the beacon signal changes during the scanning or lobing period. The monopulse approach remedies this situation by using a multi-port antenna feed and combining the feed outputs in such a way as to simultaneously generate signals proportional to  $\Delta_{az}$ ,  $\Delta_{el}$  and  $\Sigma$ . In some cases this is done with four discrete feed horns, as shown in Figure 1, and in other cases a single multi-mode horn is employed, with the  $\Delta_{az}$  and  $\Delta_{el}$  signals derived from higher-order mode couplers.

However the signals are derived, one would normally expect that three parallel receiver chains would be required to process the  $\Delta_{az}$ ,  $\Delta_{el}$  and  $\Sigma$  signals. A classic monopulse tracking system using this approach is shown in Figure 1.

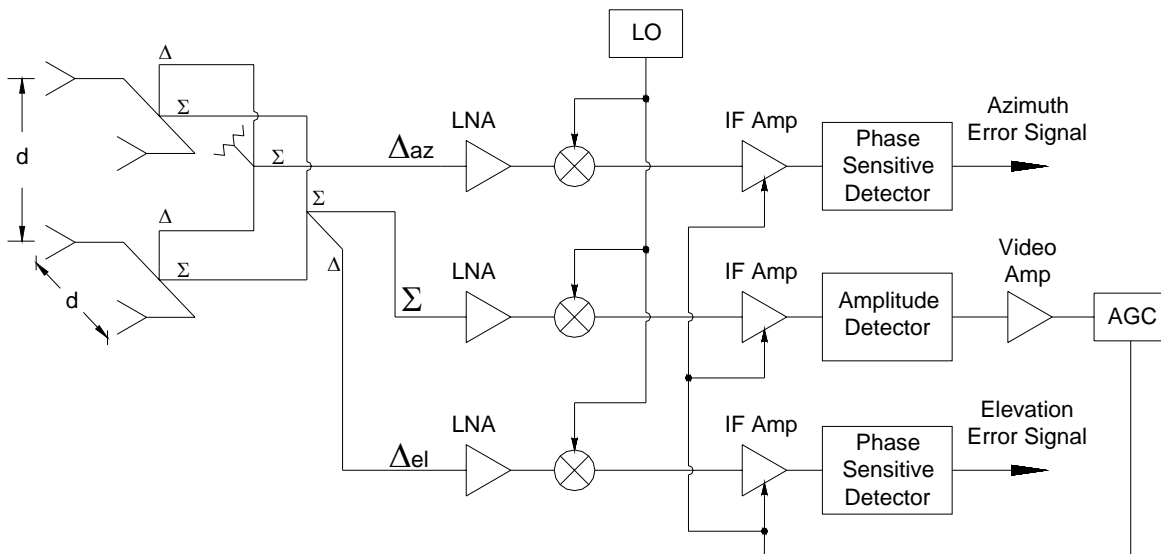

**Figure 1. A three-channel monopulse receiver system**

In spaceflight applications, building three receiver chains to achieve the autotrack function has a large impact on the size, mass, cost, power consumption, and reliability of the system. Fortunately in this application the error signals typically vary rather slowly in time, and the beacon which the system is asked to track is a very cooperative target. In this situation it is possible to combine the three error signals such that the autotrack function can be performed using a single receiver chain and a synchronous envelope detector on the receiver output, as shown in Figure 2. The resulting system is much less complex and costly than the system of

	Application Note 44X-1 • Autotrack Combiners		
	Document Description:	Date:	Revision:
<b>APPLICATION NOTE</b>	June 2002	—	Page 5 of 19

Figure 1. In addition to two of the receiver chains, the need for multiple AGC loops and phase sensitive detectors have been removed.

The autotrack combiner multiplexes the three outputs of the tracking antenna such that this simplification can be accomplished. Numerous design approaches have been used to implement the autotrack combiner function. The sections below outline some of the system aspects and performance parameters pertinent to the design of autotrack combiners, and present a number of implementations which EMS has developed for spaceflight applications over the years.

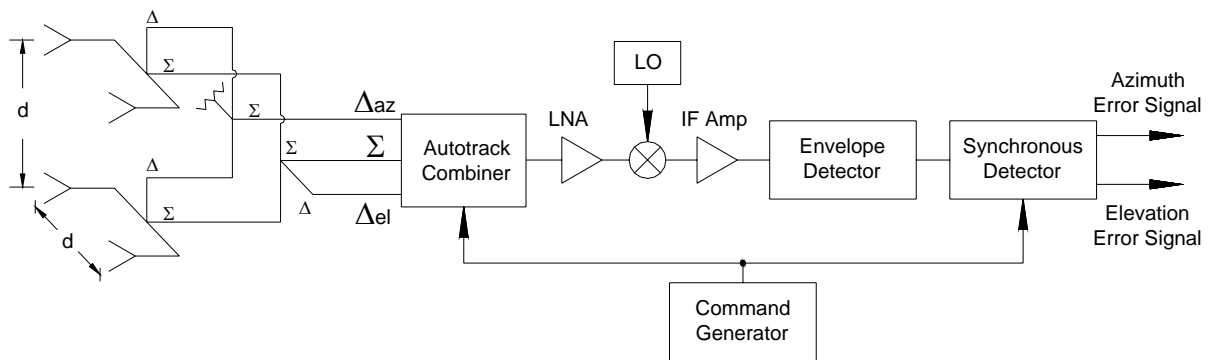

Figure 2. The autotrack combiner allows monopulse tracking to be accomplished with a single-channel receiver.

### 3 Autotrack Combiner Operation

Figure 3 shows the generic function which a 3-channel autotrack combiner must perform. The  $\Delta_{az}$  and  $\Delta_{el}$  signals are sequentially selected by a microwave switching element. The selected signals are phase shifted alternately by  $0^\circ$  and  $180^\circ$  electrical degrees relative to the  $\Sigma$  signal and combined with the  $\Sigma$  signal in a directional coupler. Figure 4 shows how synchronous detection of the envelope of the resulting RF signal allows recovery of the  $\Delta_{az}$  and  $\Delta_{el}$  signals. If we define  $V_1$  as the complex voltage amplitude of the RF signal during the time interval  $0 \leq t < T/4$  (and similarly through  $V_4$ ) then in the ideal case  $\Delta_{az}$  and  $\Delta_{el}$  can be calculated using the expressions  $\Delta_{az} = (|V_1| - |V_3|)/2k$  and  $\Delta_{el} = (|V_2| - |V_4|)/2k$ . Note that the signs of  $\Delta_{az}$  and  $\Delta_{el}$  are preserved through this operation (as they must be for proper operation of the control loop) without the use of phase-sensitive RF detectors.

In typical autotrack modulator systems for spaceflight applications  $T$  is on the order of a few milliseconds. The error terms needed for antenna pointing can thus be derived using relatively simple, inexpensive audio-frequency circuitry.

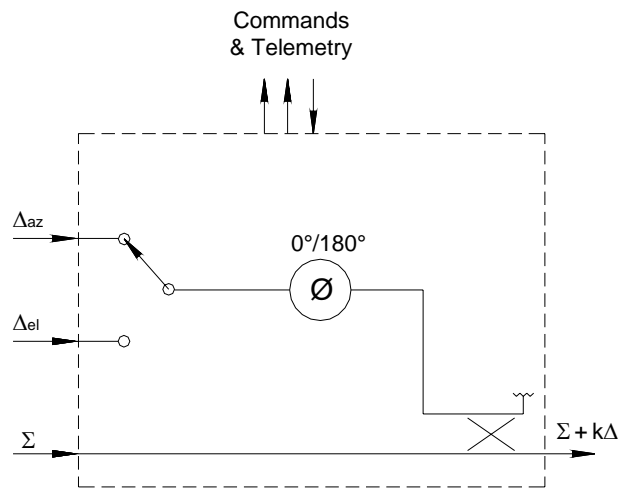

Figure 3. Generic autotrack combiner schematic

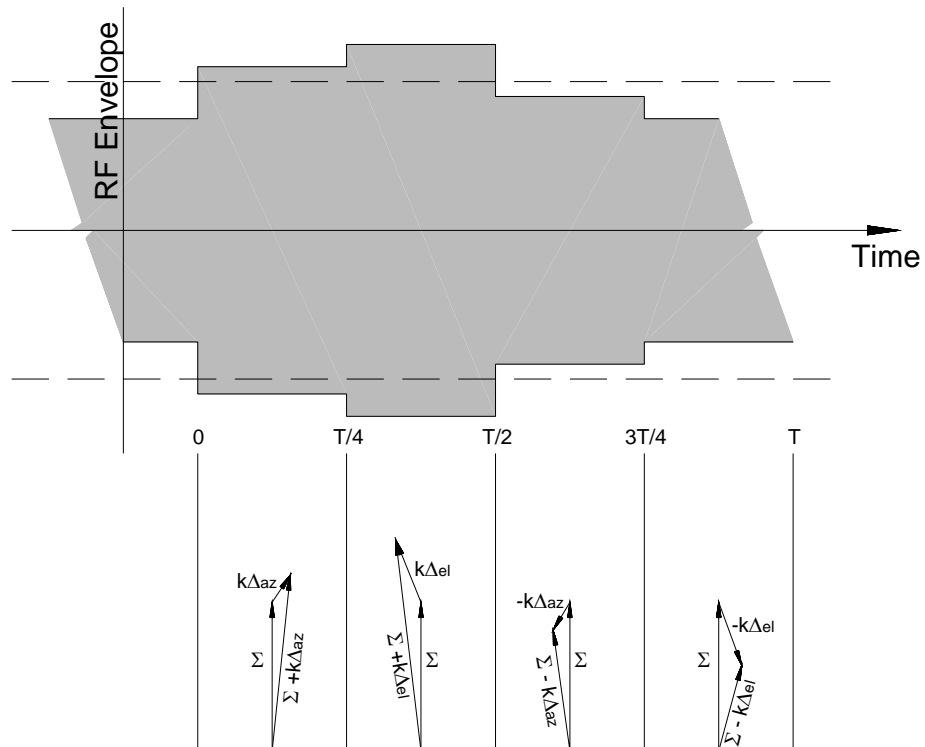

Figure 4. Coherent signal combination in the autotrack modulator. Phase errors in the  $\Delta_{az}$  and  $\Delta_{el}$  signals are exaggerated for clarity.

<b>EMSTechnologies</b>		Application Note 44X-1 • Autotrack Combiners	
<i>Document Description:</i>	<i>Date:</i>	<i>Revision:</i>	<i>Page:</i>
<b>APPLICATION NOTE</b>	June 2002	—	Page 7 of 19

The expressions for  $\Delta_{az}$  and  $\Delta_{el}$  given above are of course idealized. In practical systems, the fidelity of the derived estimates of  $\Delta_{az}$  and  $\Delta_{el}$  can be degraded by several error terms. The following section discusses these error terms, their typical magnitudes and effects.

## 4 Error Terms and Specifications for Autotrack Combiners

The error terms which significantly affect the performance of practical autotrack combiners are:

- **Insertion Loss.** The switches, phase shifters, couplers, etc. which make up the autotrack combiner all have RF losses which decrease the levels of the  $\Delta_{az}$  and  $\Delta_{el}$  signals passing through the combiner. This in turn degrades the signal-to-noise ratio of the detected  $\Delta_{az}$  and  $\Delta_{el}$  signals at the output of the synchronous detector.
- **Phase Errors.** The effects of phase errors on the autotrack combiner's output are shown in an exaggerated fashion in Figure 4. The maximum synchronously detected output signal for a given value of  $\Delta_{az}$  or  $\Delta_{el}$  is achieved when the  $\Delta$  signal is alternately combined exactly in phase and exactly  $180^\circ$  out of phase with the  $\Sigma$  signal. To the extent that this condition is not met, whether due to path length mismatches between the various feeds and the ATM, or phase setting errors within the ATM, the amplitude of the detected  $\Delta$  signal will be degraded. In the extreme case, where the  $\Delta$  signal is in quadrature with the  $\Sigma$  signal, no amplitude variation at all would be observed from modulating the phase of the  $\Delta$  signal between  $0^\circ$  and  $180^\circ$ .
- **Isolation.** The diagrams of Figure 4 assume that the switch function of the autotrack combiner is perfect. That is, on each quarter cycle, only a  $\Delta_{az}$  or  $\Delta_{el}$  signal is shown combining with the  $\Sigma$  signal. In reality, RF switches have finite isolation, and one would have, for instance in the  $0 \leq t < T/4$  interval,  $k\Delta_{az}$  plus an attenuated version of  $\Delta_{el}$  added to the  $\Sigma$  signal. Since the leaking signal can in general be in- or out-of-phase with the desired one, this can lead to degradation of the estimated  $\Delta$  signal.
- **Insertion Loss Modulation.** The diagrams of Figure 4 assume that the autotrack combiner has the same insertion loss in the  $0^\circ$  setting as it does in the  $180^\circ$  setting. If this is not the case, there is degradation in the estimate of the  $\Delta$  signal associated with this insertion loss modulation.

### 4.1 Error Analysis

Identifying these sources of error, and examining the ATM schematic of Figure 3, it is straightforward to write out expressions for the phasor voltages in the four quadrants of operation for the autotrack,  $V_1, \dots, V_4$ . They are:

<i>Document Description:</i>	<i>Date:</i>	<i>Revision:</i>	<i>Page:</i>
<b>APPLICATION NOTE</b>	June 2002	—	Page 8 of 19

$$V_1 = c\Sigma + k\varepsilon_{il}\Delta_{az}e^{j\phi_{e1}} - k\varepsilon_{iso}\Delta_{el}e^{j\phi_{e1}} \quad (1)$$

$$V_2 = c\Sigma + k\varepsilon_{il}\Delta_{el}e^{j\phi_{e2}} - k\varepsilon_{iso}\Delta_{az}e^{j\phi_{e2}} \quad (2)$$

$$V_3 = c\Sigma - k\varepsilon_{il}\varepsilon_{im}\Delta_{az}e^{j\phi_{e3}} + k\varepsilon_{iso}\Delta_{el}e^{j\phi_{e3}} \quad (3)$$

$$V_4 = c\Sigma - k\varepsilon_{il}\varepsilon_{im}\Delta_{el}e^{j\phi_{e4}} + k\varepsilon_{iso}\Delta_{az}e^{j\phi_{e4}} \quad (4)$$

Where  $\Sigma$ ,  $\Delta_{az}$  and  $\Delta_{el}$  are the outputs of the monopulse feed as discussed above, and  $c$  is the “through” loss of the directional coupler used to combine the signals. The term  $k$  is the “cross” or “coupled” loss for the directional coupler, so  $|c|^2 + |k|^2$  gives the dissipative loss of the directional coupler. The term  $\varepsilon_{il}$  gives the insertion loss of the autotrack combiner from the  $\Delta$  inputs to the combining coupler. The overall insertion loss from the  $\Delta$  inputs to the output is thus  $k\varepsilon_{il}$ . Insertion loss modulation is represented by the  $\varepsilon_{im}$  term. Isolation from the unselected  $\Delta$  input is represented by  $\varepsilon_{iso}$ . We have made the worst case assumption that the leakage signal is  $180^\circ$  out of phase with the desired signal. This gives the maximum degradation in the recovered amplitude of the  $\Delta$  signal, and is represented by the difference in sign between the second and third terms of equations (1) through (4). The phase errors between the  $\Sigma$  signal and the  $\Delta$  signal in each of the four quarter-cycles are given by the  $\phi_1$  through  $\phi_4$  terms.

As described above, the outputs of the synchronous detector are  $(|V_1| - |V_3|)/2k$  and  $(|V_2| - |V_4|)/2k$ . Using equations (1) through (4) above, it is possible to write exact expressions for these detector outputs. The result is a rather cumbersome pair of equations which are not very illustrative of the relative contributions of the error terms. For the purposes of illustration, it is better to assume that the error terms  $\varepsilon_{il}$ ,  $\varepsilon_{im}$ ,  $\varepsilon_{iso}$ , and  $\phi_1$ - $\phi_4$  only deviate slightly from their ideal values ( $\varepsilon_{il} = 1$ ;  $\varepsilon_{im} = 1$ ;  $\varepsilon_{iso} = 0$ ; and  $\phi_{e1}$ - $\phi_{e4}$  all zero). We then write the first order Taylor series expansion about this point. This gives:

$$\Delta'_{az} \approx \varepsilon_{il}\Delta_{az} + (\varepsilon_{im} - 1)\frac{\Delta_{az}}{2} - \varepsilon_{iso}\Delta_{el} + \frac{c^2\Sigma^2}{c^2\Sigma^2 - k^2\Delta_{az}^2}\Delta_{az}(\cos\phi_{e1} - 1) \quad (5)$$

$$\Delta'_{el} \approx \varepsilon_{il}\Delta_{el} + (\varepsilon_{im} - 1)\frac{\Delta_{el}}{2} - \varepsilon_{iso}\Delta_{az} + \frac{c^2\Sigma^2}{c^2\Sigma^2 - k^2\Delta_{el}^2}\Delta_{el}(\cos\phi_{e2} - 1) \quad (6)$$

$\Delta'_{az}$  and  $\Delta'_{el}$  are the degraded estimates of  $\Delta_{az}$  and  $\Delta_{el}$  due to the various error terms. We have assumed that  $\phi_{e1} = \phi_{e3}$  and  $\phi_{e2} = \phi_{e4}$  to get the worst case contribution due to phase errors. Examining these equations, we can make the following observations about the contributions of the various error terms.

- **Insertion Loss.** The signal to noise ratios ( $S/N$ ) of the  $\Delta_{az}$  and  $\Delta_{el}$  signals, and thus the accuracy of the pointing system, are directly proportional to the insertion loss of the autotrack modulator. It may be argued that insertion loss in the modulator can be compensated to some extent by changing the coupling factor  $k$  of the directional coupler combining the signals. This only works up to a point, however, since the  $\Sigma$

<b>EMSTechnologies</b>		Application Note 44X-1 • Autotrack Combiners	
<i>Document Description:</i>	<i>Date:</i>	<i>Revision:</i>	<i>Page:</i>
<b>APPLICATION NOTE</b>	June 2002	—	Page 9 of 19

signal must also pass through the combining coupler, and it contains the desired communications signal from the antenna. The coupling factor  $k$  cannot be increased arbitrarily without degrading the amplitude of the comm signal, and thus the overall noise figure of the system. If, for example, a 0.2 dB degradation in comm signal level is the maximum tolerable degradation, then the combining coupler can be no tighter than 13.5 dB. Whatever configuration of combiner is used, the  $S/N$  of the  $\Delta_{az}$  and  $\Delta_{el}$  signals are proportional to the insertion loss of the modulator. Thus, the insertion loss of the modulator is of primary importance in the performance of the autotrack system. For operation at X-band and higher frequencies, ferrite-based autotrack combiners provide the lowest insertion loss of any approach.

- Insertion Loss Modulation. The analysis shows that insertion loss modulation is not a significant factor in the performance of the autotrack system. The effect on system performance is related to the *average* insertion loss between the  $0^\circ$  and  $180^\circ$  states of the modulator. Having the insertion loss change from one state to the other does not inherently degrade the system's ability to recover the  $\Delta_{az}$  and  $\Delta_{el}$  signals. Ferrite-based modulators typically have very low insertion loss modulation.
- Isolation. The isolation term represents a cross-coupling between the  $\Delta_{az}$  signal and the  $\Delta_{el}$  signal. If the  $\Delta_{az}$  and  $\Delta_{el}$  signals are of the same magnitude, and we require no more than 0.1 dB of degradation to the  $\Delta_{az}$  signal level from the interfering  $\Delta_{el}$  signal (or vice versa) then only 16.4 dB of isolation between the two signal paths would be required. However, in general, we may be driving  $\Delta_{az}$  into a null at the same time that we have a large  $\Delta_{el}$  error. To maintain the same 0.1 dB degradation when  $\Delta_{el}$  is 20 dB larger than  $\Delta_{az}$  would require 36.4 dB of isolation between the two. A specification of 35 dB isolation between the  $\Delta_{az}$  and  $\Delta_{el}$  signal paths is typical for practical autotrack combiners. As we will see in the discussions of implementations below, this isolation is not always achieved with an RF switch. Some implementations use independent  $0^\circ/180^\circ$  phase shifters for the  $\Delta_{az}$  and  $\Delta_{el}$  signals. In these implementations the phase shifters are switched in quadrature time phase, and the isolation is achieved by subtraction of signal levels in different time intervals after the envelope detector. Isolation of 35 dB is easily achieved with a ferrite switch triad.
- Phase Errors. The  $\phi_{e1}$  and  $\phi_{e2}$  terms in equations (5) and (6) encompass both the static phase alignment errors in the transmission lines between the feed and the autotrack (and within the autotrack) as well as the phase setting accuracy of the phase shifter. They represent the phase difference between the  $\Delta_{az}$  and  $\Delta_{el}$  signals and signals which are perfectly in phase and  $180^\circ$  out-of-phase with the  $\Sigma$  signal. Examination of equations (5) and (6) shows that the phase errors are only a second order contributor to the overall  $\Delta_{az}$  and  $\Delta_{el}$  errors. The system can tolerate relatively large phase setting errors. A phase error of  $8.7^\circ$  is required to cause a 0.1 dB degradation in the  $S/N$  ratio of the  $\Delta_{az}$  and  $\Delta_{el}$  estimates. A phase error of  $12.2^\circ$  causes a 0.2 dB degradation, and a phase error of  $15^\circ$  is required to cause a 0.3 dB degradation. Phase error levels of  $8^\circ$  peak can readily be achieved with both ferrite switch- and ferrite phase shifter-based autotrack combiners.

<b>EMSTechnologies</b>		Application Note 44X-1 ● Autotrack Combiners	
<i>Document Description:</i>	<i>Date:</i>	<i>Revision:</i>	<i>Page:</i>
<b>APPLICATION NOTE</b>	June 2002	—	Page 10 of 19

## 4.2 Other Error Sources and Requirements

Other parameters which are typically specified for autotrack modulators include switching rate, switching time, VSWR, command and telemetry interface, as well as the usual size, mass, power consumption, reliability, lifetime, EMC/EMI, etc. which are specified for any spaceflight equipment.

- **Switching Rate.** Since the signals recovered from the autotrack combiner are used to drive mechanical servos, a fairly low modulation frequency (relative to the capability of modern electronic circuits) is usually adequate for the application. Autotrack combiners typically operate with modulation frequencies in the 100 to 400 Hz range. For ferrite-based autotracks, the power consumption is directly proportional to the switching rate, so lower-frequency modulations are preferable.
- **Switching Time.** During the transition time between one phase setting and another, the output of the autotrack combiner cannot be used. The  $\Delta_{az}$  and  $\Delta_{el}$  estimates are degraded by the fraction of the total time line of the autotrack which is taken up by the switching time. Typically this is not a concern. Ferrite-based autotracks can switch in 10  $\mu$ s or less and diode base units are even faster. In either case, with a 10 ms switching period the resulting ~0.1% degradation in the  $\Delta$  signal is negligible.
- **VSWR.** Interactions between the mismatches at the antenna feed and the autotrack can cause amplitude and phase errors which degrade signal recovery. Ferrite-based autotracks can generally achieve 20 dB return loss over all operating conditions, minimizing VSWR problems.
- **Command and Telemetry.** Typically, RS-422 interfaces are used for command and telemetry of the autotrack combiner. The autotrack changes state as a result of a logic transition on one of its inputs. A few tens of microseconds after this transition, telemetry is available at the output to confirm proper operation of the autotrack for that transition.

The other specified parameters are generally dictated by the orbit, application, and design lifetime of the particular spacecraft involved. By adjusting shielding, heat sinking, and driver circuit topology, a wide range of these parameters can be accommodated.

<b>EMS</b> Technologies	Application Note 44X-1 ● Autotrack Combiners		
<i>Document Description:</i>	<i>Date:</i>	<i>Revision:</i>	<i>Page:</i>
<b>APPLICATION NOTE</b>	June 2002	—	Page 11 of 19

### 4.3 *Practical Considerations: Phase Trimming*

As described above, operation of the autotrack combiner requires that the proper electrical phase relationship be maintained between the  $\Sigma$ ,  $\Delta_{az}$  and  $\Delta_{el}$  signals as they pass from the antenna to the combiner output. This generally requires phase trimming in the lines connecting the various antenna ports to the autotrack combiner. As will be seen in the sections below on implementations, this trimming can often be accomplished by simple waveguide length extensions or shims, due to the relatively narrow frequency band of typical autotrack beacons. Several of EMS' switch-based autotrack modulators were required to include provisions for "select-at-integration" waveguide trombone sections to accommodate this phase trimming. Diode- and transistor-based switched-line modulators use similar mechanical shimming approaches to equalize line lengths.

Practical difficulties sometimes arise in the select-at-integration shimming process, however. To achieve the desired compensation, the shims must be selected and installed after the full antenna system has been integrated and is in test. The waveguide interconnects between the antenna and modulator can be fairly complex, with VSWR interactions between numerous components in the path. Inserting a length of line in the path changes the phasing of these interactions and can give unexpected phase errors which are difficult to model and predict. This can result in the shim selection being an iterative process which is difficult and time consuming. Since it involves the full-up antenna system on a costly antenna test facility, the shim selection process can become an expensive proposition.

The need for mechanical shimming in the antenna system can be totally eliminated by the use of a high-resolution ferrite phase shifter in the autotrack modulator. A phase shifter with 8-bit resolution is typical for the autotrack modulator application. This gives a setting resolution of  $\pm 0.7^\circ$ . By choosing the appropriate pairs of 8-bit commands, the modulating phase shifter can both provide the desired  $0^\circ/180^\circ$  switching and trim the insertion phase of the various paths to this accuracy. Since the process of selecting the appropriate commands does not involve the removal and replacement of RF components, there is no time-consuming iterative process. EMS has extensive spaceflight heritage with high-accuracy, high-resolution ferrite phase shifters for spaceflight applications.

The 8-bit codes required for selecting the desired phase settings can be programmed in a number of ways. In some cases they are entered into the memory of one of the spacecraft's control computers and in others they are programmed into local memory in the autotrack combiner electronics using jumper plugs or electrically programmable ROMs.

<b>EMS Technologies</b>		Application Note 44X-1 • Autotrack Combiners	
<i>Document Description:</i>	<i>Date:</i>	<i>Revision:</i>	<i>Page:</i>
<b>APPLICATION NOTE</b>	June 2002	—	Page 12 of 19

## 5 Examples of Autotrack Combiner Implementations

The following sections describe several examples of spaceflight autotrack combiners that EMS has delivered over the years. They cover a fairly broad range of architectures, frequency ranges and physical configurations. These examples are provided to the customer as a catalog of our capabilities. Any of these configurations, or combinations thereof, can be tailored to the customer's specific requirements.

### 5.1 Dual Phase Shifter/Tee Autotrack Combiner

Figure 5 shows the schematic of an autotrack combiner implementation using two  $0^\circ/180^\circ$  phase shifters placed between magic tees (or any other type of  $0^\circ/180^\circ$  directional coupler). When the two phase shifters are commanded to the same settings ( $0^\circ-0^\circ$  or  $180^\circ-180^\circ$ ), the  $\Delta_{el}$  signal appears at the output of the modulator, with a  $0^\circ$  or  $180^\circ$  phase shift. When the phase shifters are commanded in opposition ( $0^\circ-180^\circ$  or  $180^\circ-0^\circ$ ) the  $\Delta_{el}$  signal is routed into the magic tee's load and the  $\Delta_{az}$  signal appears at the output.

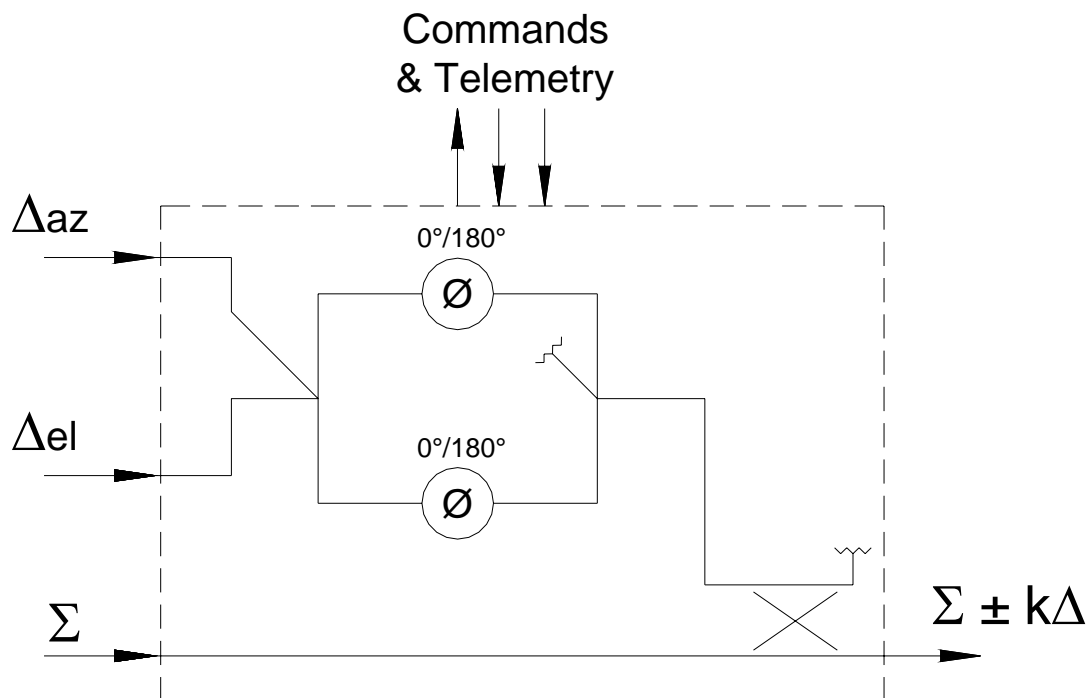

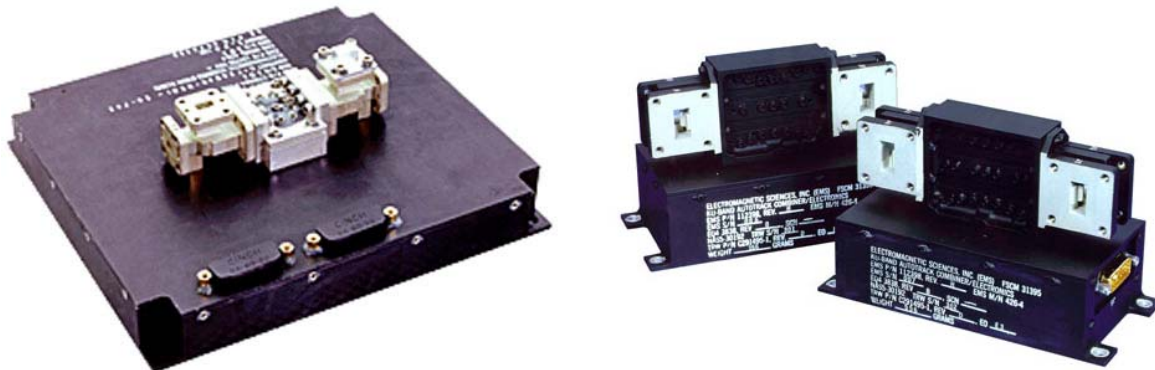

Figure 5. Autotrack modulator configuration incorporating dual  $180^\circ$  phase shifters between magic tees.

	Application Note 44X-1 • Autotrack Combiners		
	Document Description:	Date:	Revision:
APPLICATION NOTE	June 2002	—	Page 13 of 19



**Figure 6. Phase shifter/tee autotrack modulators built for the ACTS (left) and TDRS A-G (right) spacecraft. The ACTS unit operates at K<sub>a</sub>-band and the TDRS unit at K<sub>u</sub>-band.**

Figure 6 shows two implementations of the phase shifter/tee autotrack modulator. The unit on the left flew on NASA's Advanced Communications Technology Satellite (ACTS), and operates in K<sub>a</sub>-band. The unit on the right is a K<sub>u</sub>-band unit which flew on the first six of NASA's Tracking and Data Relay Satellite (TDRS) spacecraft.

The chief advantages of the phase shifter/tee autotrack modulator are its low insertion loss and compact package size. The low insertion loss results from the fact that there is no separate RF switching device (such as a ferrite junction switch) to select between  $\Delta_{az}$  and  $\Delta_{el}$ . The switching is accomplished by proper choices of the phase shifter settings. Thus the insertion loss in the RF path is just that of two waveguide magic tees and a ferrite phase shifter. Insertion loss of 1.0 dB is readily attainable at K<sub>u</sub> band.

To achieve low insertion loss, the phase shifter/tee autotrack compromises on isolation. In trying to achieve high isolation, the phase shifter/tee autotrack is essentially an interferometer being driven into a null: the null depth (and thus the isolation) depends strongly on the phase setting accuracy of the two phase shifters and the amplitude balance between the two halves of the modulator. This type of modulator typically achieves 30 dB of isolation between the desired and undesired  $\Delta$  signals.

Because both ATMs shown in Figure 6 use fixed 0°/180° phase shifters, it was still necessary to shim the input waveguides with these units to achieve the required phase matching of the  $\Sigma$  and  $\Delta$  signals. It would be possible in this configuration to change to 360° phase shifters in the arms of the autotrack. Then the required phase trimming could be accomplished by selecting appropriate phase commands which are 180° apart but have the correct average phase to compensate for line length mismatches. Switching from 180° to 360° phase shifters would increase the insertion loss of the ATM by about 0.3 dB at K<sub>u</sub> band.

	Application Note 44X-1 • Autotrack Combiners		
	Document Description:	Date:	Revision:
APPLICATION NOTE	June 2002	—	Page 14 of 19

## 5.2 Switched Line Autotrack Modulator

Figure 7 shows the schematic of a switched line autotrack combiner. In this configuration, ferrite junction switches are used to sequentially select lengths of waveguide delay line to provide the desired phase shifts. This configuration has a number of interesting features. At first glance it may appear that this design gives up 3 dB of signal level on the  $\Delta_{az}$  and  $\Delta_{el}$  signals since they are combined in a 3 dB hybrid instead of being multiplexed by an RF switch. With proper sequencing of the phase shifters feeding the hybrid, and proper post-processing of the synchronously detected signal, however, this loss becomes a moot point.

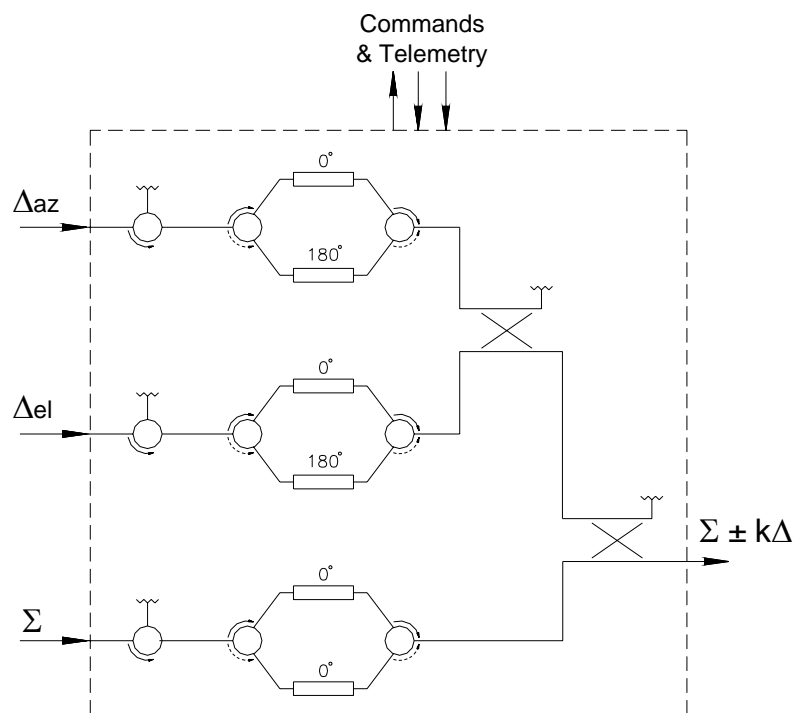

**Figure 7. Schematic of a switched-line autotrack modulator. Switched-line modulators with ferrite switches offer the lowest insertion loss of any ATM approach.**

As described above, the switches and phase shifters of the generic autotrack of Figure 3 operate to divide the timeline into four quarter-periods. In these periods, the outputs of the combiner are  $c\Sigma + k\Delta_{az}$ ;  $c\Sigma + k\Delta_{el}$ ;  $c\Sigma - k\Delta_{az}$ ; and  $c\Sigma - k\Delta_{el}$ , respectively. With the ATM of Figure 7, the corresponding signals are  $c\Sigma + k\Delta_{az} / \sqrt{2} + k\Delta_{el} / \sqrt{2}$ ;  $c\Sigma + k\Delta_{az} / \sqrt{2} - k\Delta_{el} / \sqrt{2}$ ;  $c\Sigma - k\Delta_{az} / \sqrt{2} + k\Delta_{el} / \sqrt{2}$ ; and  $c\Sigma - k\Delta_{az} / \sqrt{2} - k\Delta_{el} / \sqrt{2}$ . While the first approach does not take the 3 dB hit from the combiner, we only get to see each of the  $\Delta_{az}$  and  $\Delta_{el}$  signals for half of the timeline. With the second approach, both error signals are visible through the entire timeline, but at a reduced amplitude level. After synchronous

<b>EMS</b> Technologies	Application Note 44X-1 • Autotrack Combiners		
<i>Document Description:</i>	<i>Date:</i>	<i>Revision:</i>	<i>Page:</i>
<b>APPLICATION NOTE</b>	June 2002	—	Page 15 of 19

envelope detection and time integration over the full period, these two approaches are equivalent.

Since the synchronous detector separates the  $\Delta_{az}$  and  $\Delta_{el}$  signals, modulators using the configuration of Figure 7 do not typically have any specification for isolation. The insertion loss of this type of modulator is quite low, due to the low insertion loss of ferrite junction switches and the use of waveguide for all interconnects. An insertion loss of 0.7 dB (in addition to the 3 dB hybrid loss) for a switched line autotrack modulator is typical at  $K_u$  band. Figure 8 shows a  $K_a$  band switched line autotrack modulator. In this model, as shown in the schematic, a  $0^\circ/0^\circ$  phase shifter is added in the  $\Sigma$  path. This equalizes the path lengths between the  $\Sigma$  and  $\Delta$  signals and optimizes phase tracking over temperature and frequency.

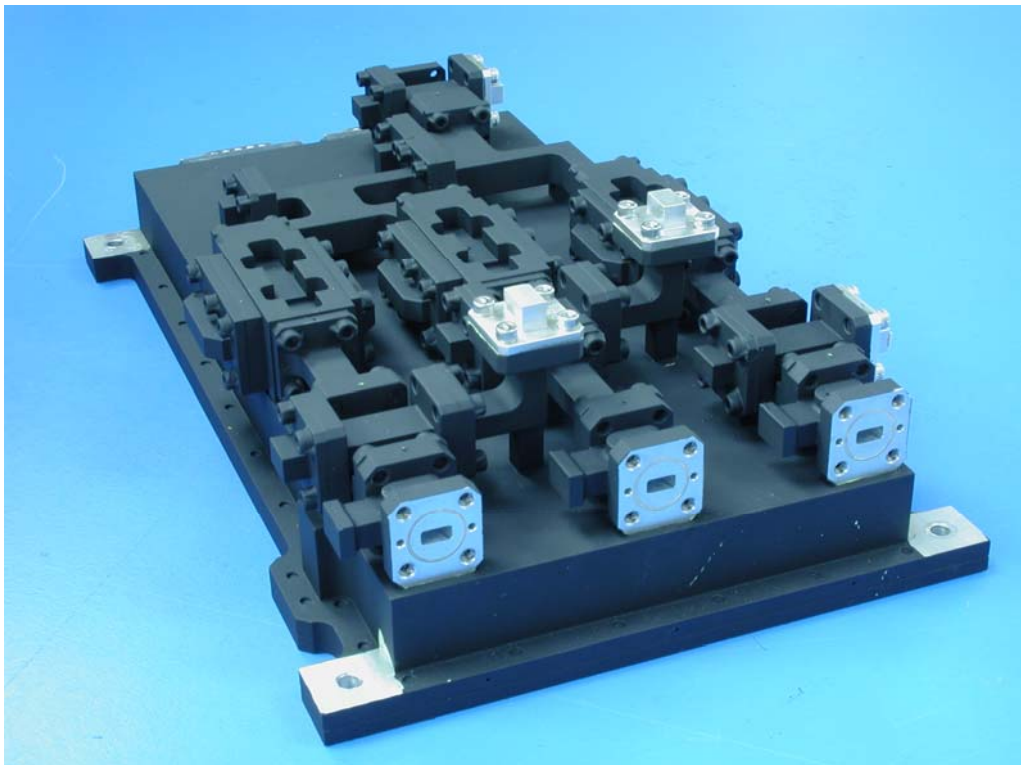

**Figure 8. A  $K_a$ -band switched line autotrack modulator. This unit includes sampling couplers on all of the input ports for use in alignment.**

The only disadvantage with this type of modulator is that mechanical shimming is still required to compensate for phase errors in the waveguide runs between the antenna and the ATM. This limitation is overcome by the phase shifter based autotrack modulator as described in the following section.

<b>EMS</b> Technologies	Application Note 44X-1 • Autotrack Combiners		
Document Description:	Date:	Revision:	Page:
<b>APPLICATION NOTE</b>	June 2002	—	Page 16 of 19

### 5.3 Phase Shifter Based Autotrack Modulator

Figure 9 shows the schematic of a phase shifter based autotrack modulator. This configuration uses a high-isolation RF switch to multiplex the  $\Delta_{az}$  and  $\Delta_{el}$  signals into a high-resolution ferrite phase shifter. The output of this type of autotrack combiner is as shown in Figure 4, and the  $\Delta_{az}$  and  $\Delta_{el}$  signals can be recovered by synchronous envelope detection.

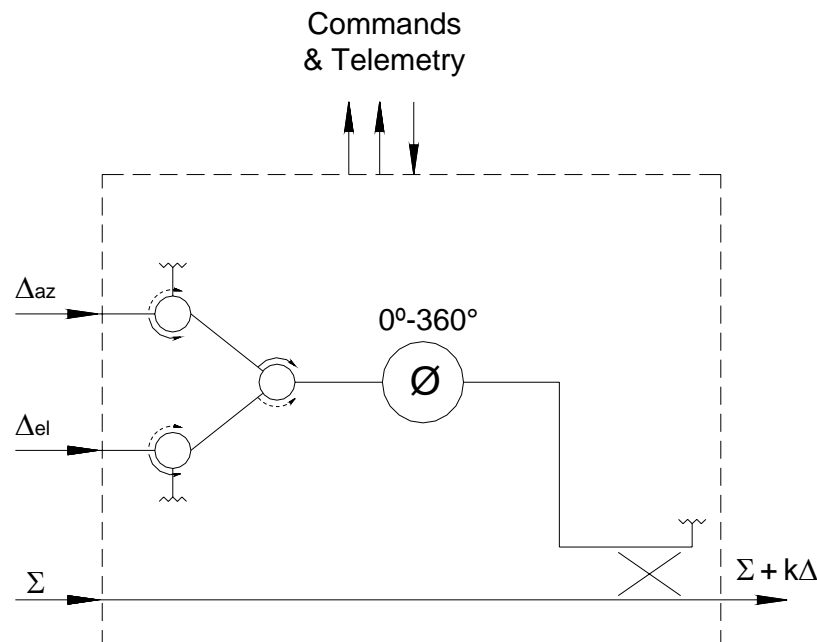

**Figure 9. The phase shifter based autotrack modulator incorporates a high-isolation RF switch and a high-resolution ferrite phase shifter. The high-resolution phase shifter enables electronic phase trimming within the autotrack.**

As described in § 4.3, this type of autotrack can provide electronic phase compensation for alignment of the antenna system by choosing the appropriate pairs of phase commands which are  $180^\circ$  apart anywhere in the  $0^\circ$ - $360^\circ$  range of the variable phase shifter. This enables flexibility beyond just the resulting simplification of final antenna system integration and test. For example, in some cases it is desirable for the autotrack system to have the ability to work with a number of beacons distributed across a fairly wide frequency band. It is often desirable to change which beacon a given autotrack is working with, even after spacecraft launch. This is practically impossible with a mechanically trimmed system. With the phase shifter based ATM, the system can be characterized at any number of beacon frequencies, and the appropriate codes for phase equalization stored for later use.

	Application Note 44X-1 • Autotrack Combiners		
	Document Description:	Date:	Revision:
APPLICATION NOTE	June 2002	—	Page 17 of 19



**Figure 10.** This phase shifter based autotrack modulator is currently flying on NASA's TDRS H, I, and J spacecraft. It consists of a single driver and control electronics box with two RF heads, one in  $K_u$  band and one in  $K_a$  band.

Figure 10 shows the phase shifter based autotrack which is currently flying on NASA's TDRS spacecraft, models H, I and J. This unit has two RF heads, one operating at  $K_u$ -band and the other at  $K_a$ -band. In both bands, the ferrite switch triads achieve  $> 40$  dB of isolation between the  $\Delta_{az}$  and  $\Delta_{el}$  signals. The insertion loss of the  $K_u$ -band RF head is  $< 1.2$  dB, and that of the  $K_a$ -band head is  $< 1.4$  dB.

#### **5.4 Phase Shifter Only Autotrack Modulator**

In some tracking antenna feeds, the  $\Delta_{az}$  and  $\Delta_{el}$  signals are combined in RF quadrature at the antenna. This is an inherent property of some multimode circularly polarized monopulse feed horns that use higher-order mode couplers to generate the difference patterns. In order to multiplex this combined  $\Delta_{az}/\Delta_{el}$  signal with the  $\Sigma$  signal such that  $\Delta_{az}$  and  $\Delta_{el}$  can be separated at the IF, it is necessary for the modulator to phase shift the composite error signal in a  $0^\circ/90^\circ/180^\circ/270^\circ$  sequence. The schematic of such a modulator is shown in Figure 11.

<b>EMS</b> Technologies	Application Note 44X-1 • Autotrack Combiners		
<i>Document Description:</i>	<i>Date:</i>	<i>Revision:</i>	<i>Page:</i>
<b>APPLICATION NOTE</b>	June 2002	—	Page 18 of 19

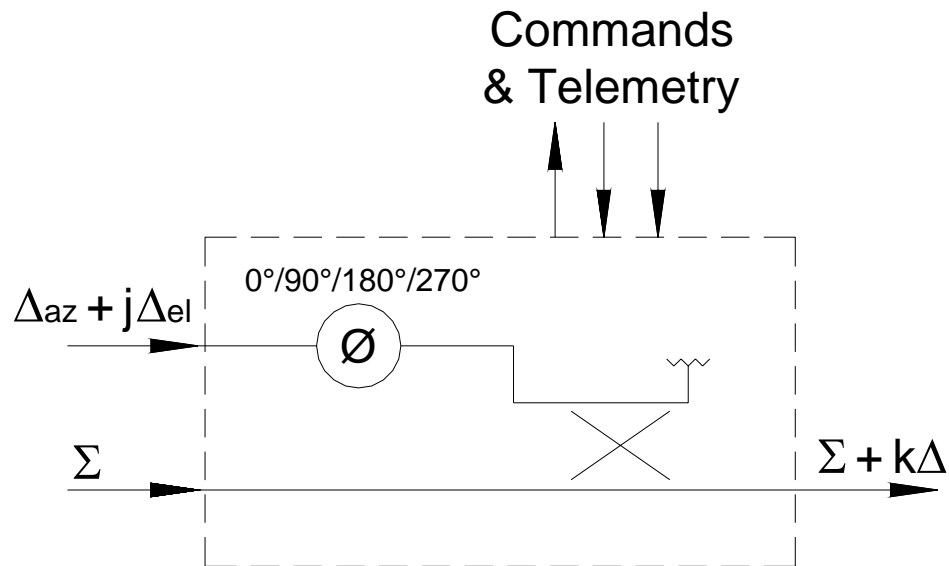

**Figure 11. In the phase shifter only autotrack modulator, the composite error signal is sequentially phase shifted in quadrature steps.**

Figure 12 shows a phase shifter only autotrack modulator which is currently flying on the MILSTAR spacecraft. The phase shifter only autotrack has the same capabilities for electronic phase trimming and multi-frequency operation as were described in the previous section on phase shifter based autotrack modulators.

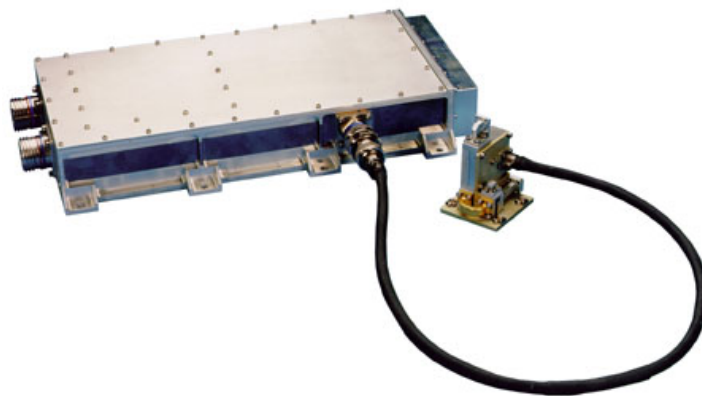

**Figure 12. A phase shifter only autotrack modulator.**

<b>EMS Technologies</b>	Application Note 44X-1 • Autotrack Combiners		
<i>Document Description:</i>	<i>Date:</i>	<i>Revision:</i>	<i>Page:</i>
<b>APPLICATION NOTE</b>	June 2002	—	Page 19 of 19

## 6 Summary

The autotrack combiner provides a means of multiplexing all of the RF error signals needed to steer a tracking antenna onto a single carrier. It thereby frees up valuable receiver electronic hardware for communications throughput. Ferrite-based autotrack combiners offer low loss, high reliability and low performance drift over life. Autotracks incorporating high-resolution ferrite phase shifters offer the capability to electronically trim out phase errors in the antenna feed and interconnecting transmission lines during top level antenna testing. Figure 13 shows a sampling of ferrite-based autotrack modulators which EMS Technologies has delivered for demanding spaceflight applications over the years.

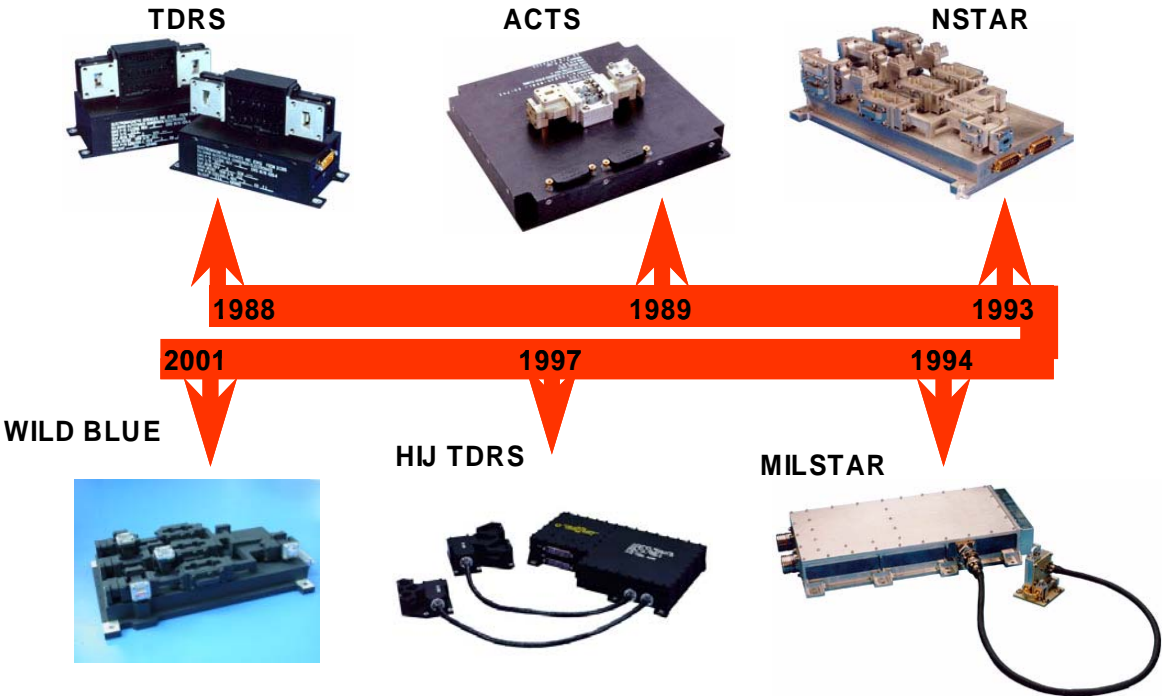

Figure 13. A sampling of EMS Technologies' heritage in spaceflight autotrack modulators.